



Headquarters: 2145 Indian Road | West Palm Beach, Florida 33409 | Phone (888) or (561) 616-9003 | Fax (561) 616-9005
West Coast Branch: 11947 E. Florence Ave, Ste 5 | Santa Fe Springs, CA 90670 | Phone (562) 903-0004 | Fax (562) 903-0006

Doublewide Stirrup

Instruction Manual



Description

The Doublewide Stirrup is designed to connect 2 parallel Altrex or UP-STAGE platforms up 33 ft (using 1000 lb hoists) or 50 ft (using 1500 lb hoists). The resulting 5 ft wide platform is ideal to provide access underneath overhangs without the need for a custom built platform.

Specifications

- Part No.:** 934118
- Description:** Doublewide Stirrup
- Load Capacity:** 1500 lb incl. 4:1 safety factor
- Dimensions:** 52x3x63 in. (HxDxW)
- Weight:** 80 lb
- Construction:** Steel
- Finish:** Powder Coat



Headquarters: 2145 Indian Road | West Palm Beach, Florida 33409 | Phone (888) or (561) 616-9003 | Fax (561) 616-9005
West Coast Branch: 11947 E. Florence Ave, Ste 5 | Santa Fe Springs, CA 90670 | Phone (562) 903-0004 | Fax (562) 903-0006

GENERAL WARNING - Read First

**Safety is a matter of life or death for riggers, operators and by-standers.
This warning is your share of duties for achieving safety.**

Your duty to understand and comply:

1. It is imperative for safety and efficiency of operations that this manual be read and fully understood by the rigger and the operator before rigging and using this equipment. All instructions contained herein must be carefully and strictly followed, including applicable Bee Access guidelines.
2. Should you hand over this equipment under any conditions, to any party operating out of your control, you must attach a clean copy of this manual and draw to other party's attention that strictly following all the instructions therein is a matter of life or death.
3. Before using this equipment, the rigger and the operator must become aware of all requirements of federal, state, provincial and local safety regulations, applicable to the entire suspended scaffold system and any component of it.
4. Never load this equipment above its rated load of **1500 lbs.**
5. Bee Access declines any responsibility for any special layouts, rigging or structural combinations beyond the descriptions of this manual.
6. Bee Access declines any responsibility for any other use of this equipment, than described in this manual.

Your duty to inspect and maintain:

7. Keep this manual available at all times for easy reference whenever required. Extra copies are available from Bee Access and/or your equipment supplier.
8. Carefully take notice of all labels affixed to the equipment. Never rig or operate this equipment if any label, normally fixed on it is obscured or missing. Replacement labels are available from Bee Access and/or your equipment supplier.
9. Every time the suspended scaffold is to be rigged or used, check that the Tieback Anchor, rigging, hoists, platform and other components are complete and in good working condition, prior to proceeding. All wire ropes and safety lines and their protective sleeves should be inspected at the beginning of every shift. Check for wear and abrasion due to contact with rigging equipment and/or the building structure.
10. **Inspection is to be carried out by personnel authorized by Bee Access once every 6 months.** Thoroughly check overall condition for excessive corrosion and bent, damage or worn parts or broken welds. A signed and dated inspection record should be maintained for these purposes.
11. Make sure to comply with inspection and maintenance guidelines of all other components used in the suspended scaffold system.
12. Bee Access declines any responsibility for consequences of repairs or modifications brought out of its control to the product, specifically by replacement of original parts or repairs by another manufacturer.

Your duty to train and control people:

- Compliance with safety rules extends to rigging operations which must be carried out only after securing safe conditions of operation as per safety regulations and requirements.
13. An operator must not be assigned to rigging, de-rigging, moving or operating a suspended scaffold if that person is not:
 - a. Mentally and physically fit for the purpose, especially at heights
 - b. Competent for the job to be performed
 - c. Familiar with the scaffold equipment as rigged
 - d. Professionally trained for working under the above requirements
 14. Never let the equipment be moved or operated by unauthorized personnel. Keep the equipment, either rigged or unrigged, out of reach of unauthorized persons, while out of operation.
 15. Every suspended job must be placed under the control of a person having the required competence and authority for checking that all the instructions prescribed by this manual be regularly and efficiently carried out.

Your duty to safety of the entire scaffold system:

- A suspended scaffold system is made up of numerous pieces of equipment; all of these components can contribute to the required safety only if:
16. Other components meet the requirements of the applicable safety regulations and requirements, are of the proper quality, assembled to form a safe and efficient suspended system and compatibility is approved by Bee Access.
 17. The supporting structure and tie-backs can withstand every load to be applied, either static or dynamic, during rigging or operating of the suspended scaffold equipment.
 18. All the requirements in strength and resistance are obtained with the necessary safety coefficients (call your supplier for regulations and professional standards).
 19. All the calculations, design and subsequent work necessary to meet the above requirements have been made by a competent person on the basis of proper technical information regarding the site.

NOTE: This manual is neither a regulations compliance manual nor a general training guide on suspended scaffold operations. You must refer to proper instructions delivered by your supplier of the other pieces of equipment included in your suspended scaffold installation. Whenever calculations and specific rigging and handling are involved, the operator should be professionally trained to that end and secure relevant information prior to commencing such work.

Read and comply with the "Code of Safe Practices for Suspended Powered Scaffolds" issued by the Scaffold Industry Association (also available from Bee Access or your supplier).



Headquarters: 2145 Indian Road | West Palm Beach, Florida 33409 | Phone (888) or (561) 616-9003 | Fax (561) 616-9005
West Coast Branch: 11947 E. Florence Ave, Ste 5 | Santa Fe Springs, CA 90670 | Phone (562) 903-0004 | Fax (562) 903-0006

Doublewide Stirrup

Assembly Instructions

Tools Required:

1. Ratchet, 1/2" drive
2. Socket, 3/4 & 1-1/8".
3. 3/4" wrench
4. Adj. wrench-12"

NOTE:

Assembly must be performed or supervised by a competent and trained person. Read and fully understand these instructions before proceeding with installation.

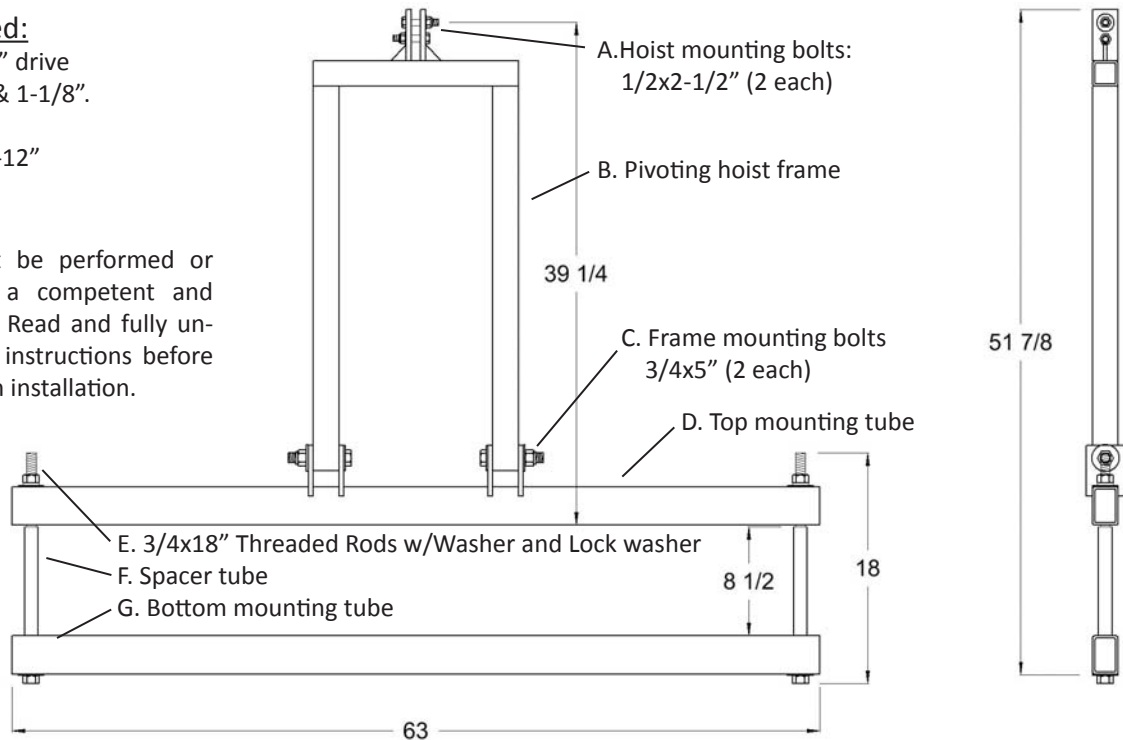

Assembly Instructions:

1. Position the two platforms next to each other, making sure that the trusses on each parallel section match.
2. Slide the Top mounting tube (D) over the toeboards and through the midrail trusses of the platforms in the desired position.
3. Slide the Bottom mounting tube (G) underneath the platforms.
4. Insert the 18" Threaded Rods (E) with flat washer through the Bottom Tube (G).
5. Slide Spacer tube (F) over Threaded Rod (E).
6. Mount this assembly to the Top mounting tube (D) using a flat washer, lock washer and 3/4" nut. Tighten nut until the slack is taken out of the Spacer tube (F). Stop tightening and do not unnecessarily overtighten.
7. Mount Pivoting hoist frame (B) to Top mounting tube (D) with 3/4x5" bolts, washers and locknut. Tighten locknut until it is just taut, do not overtighten.

1. Mount hoist to Pivoting hoist frame (B) with hoist mounting bolts (A). Tighten locknuts until they are just taut, do not overtighten.
2. Load capacities are identical to single width platforms. Refer to the platform load charts in the manual or on the labels attached to the Side frames.
3. Use appropriately rated hoists for the platform self weight plus the desired load capacity. Examples:
 - a. 20 ft length + 1000 lb load capacity= 1000 lb hoists
 - b. 30 ft length + 750 lb load capacity= 1000 lb hoists
 - c. 33 ft length + 500 lb load capacity= 1000 lb hoists
 - d. 36 ft length + 1000 lb load capacity= 1500 lb hoists
 - e. 50 ft length + 750 lb load capacity= 1500 lb hoists

WARNING:

- Any installation of this equipment other than in strict accordance with these instructions shall be at the Operator's risk and may result in death or serious injury.

Spare parts used for all equipment must be in accordance with the product, no substitutions are allowed.

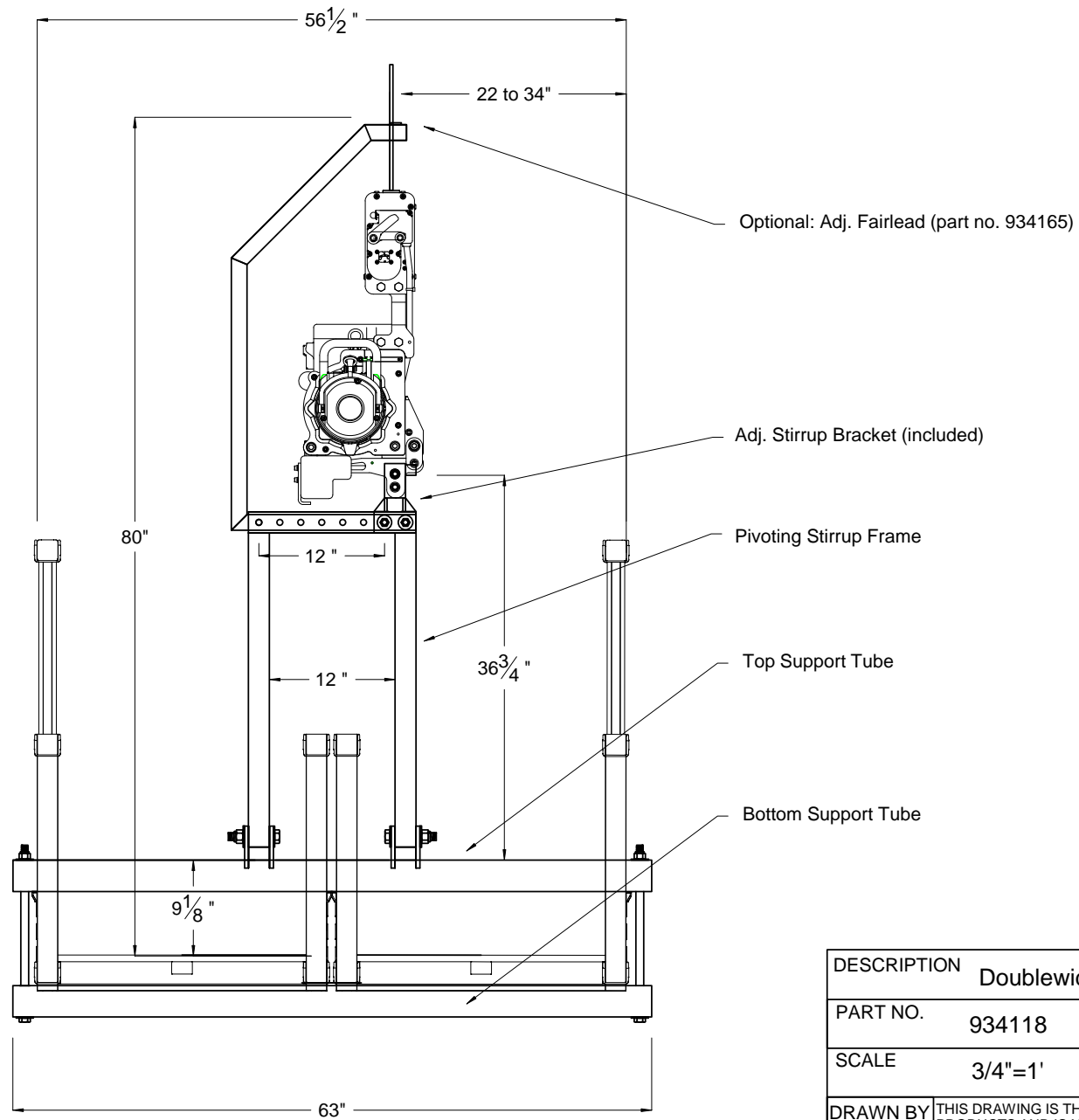

DESCRIPTION		Doublewide Stirrup w/Fairlead	
PART NO.	934118	DATE	1/7/11
SCALE	3/4"=1'	REVISION NO.	
DRAWN BY	THIS DRAWING IS THE PROPERTY OF BEE ACCESS PRODUCTS AND IS NOT TO BE COPIED OR REPRODUCED WITHOUT THE CONSENT OF BEE ACCESS PRODUCTS.		
TDJ			
 Bee Access Products			

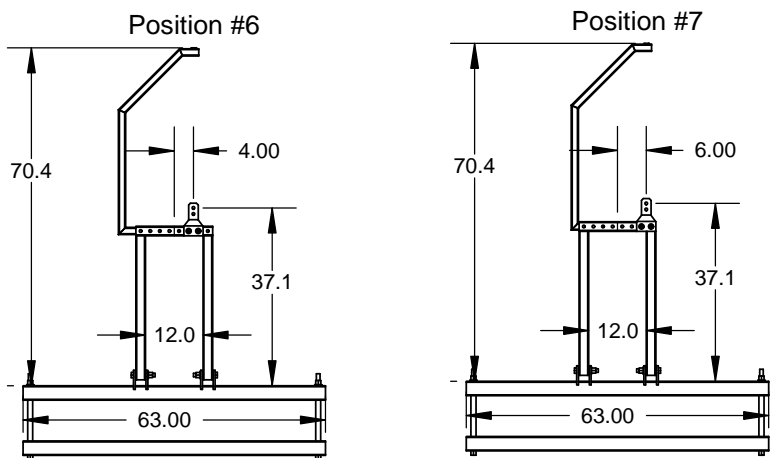
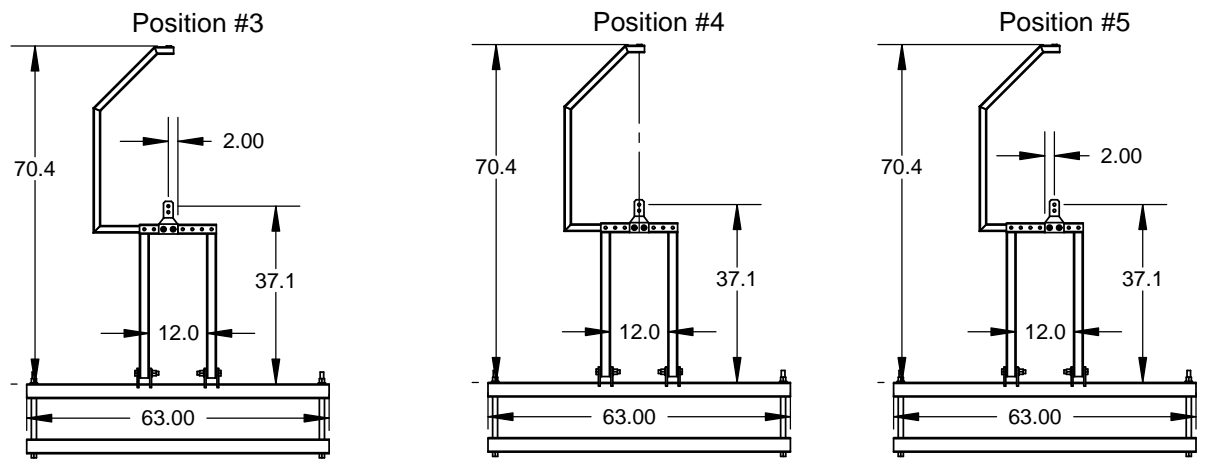
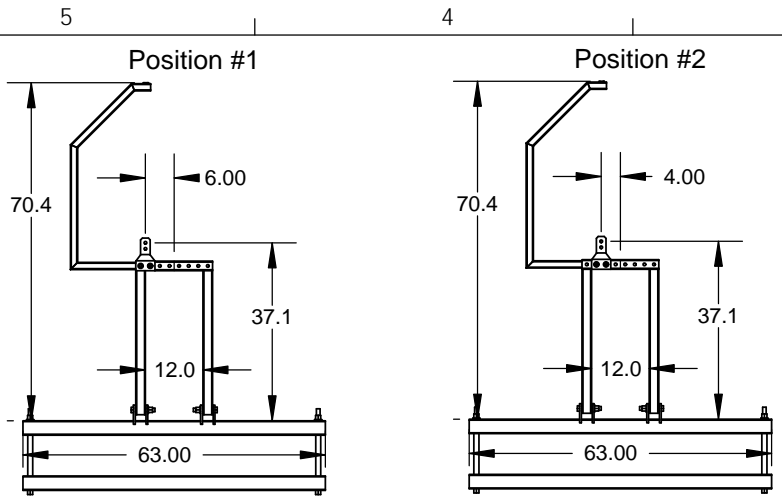

ITEM NO.	QTY.	PART NO.	DESCRIPTION
1	1	934118-1	Stirrup Frame, 934118
2	1	934118-2	Mounting Bracket Weldment
3	1	934118-5	Double Wide Stirrup, Base Weldment
4	1	934118-51	Double Wide Stirrup, Base Tube
5	2	934118-6	Double Wide Stirrup, Spacer
6	2	934118-7	3/4" All Thread, 17"
7	4	110481	Washer, 3/4" Flat
8	2	110482	Washer, 3/4" Lock
9	2	110383	Nut, 3/4" SS
10	2	110284	Bolt 3/4"-10 x 4.5"
11	2	110382	Nut, Lock 3/4"-10
12	2	110253-5	Bolt 1/2"-13 x 3.5"
13	2	110352	Nut, Lock 1/2"-13
14	2	110451	Washer, 1/2" Flat
15	1	934165	Adjustable Fairlead, Double Wide Stirrup

NOTE:
Item #15 (Adj. Fairlead) is optional

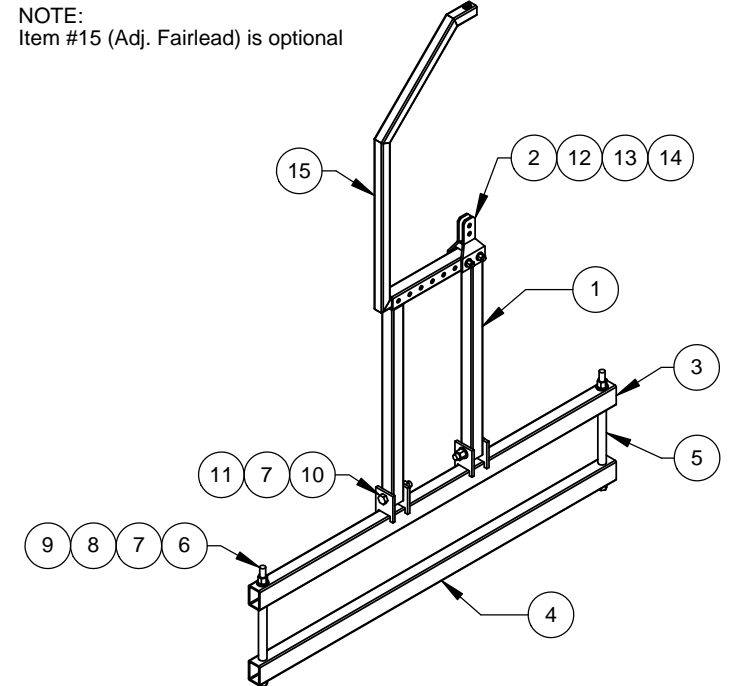

B	Reduced bolt length	BJA	06-19-15
REV	Revision Description	By	Date
DEBUR AND BREAK SHARP EDGES			
Material: Assembly		Weight: 123 LBS	
Treatment: N/A			
Raw material part number:	Dimensions in [] are in mm Tol. ISO 2768-m		
Assembly	>	0,5	6 30 120 400
	<	6	30 120 400
Scale Size 1:40 B/A3	TOL.	±0.1	±0.2 ±0.3 ±0.5 ±0.8
	Machined surfaces	12.5	
CAD generated drawing. Do not manually update. Do not scale drawing.		ISO 1302	
Unless otherwise stated tolerances in inches		Product Line/Project: Platform	
Approvals	By: Date:	Fractions	Decimals
Drawn	BJA 07-01-13		X ± .060 XX ± .015 XXX ± .005
Approved	XX-XX-XX		ALL ± .5°
		REV. B	
		Part No. 934118	
		Sheet 1 of 1	

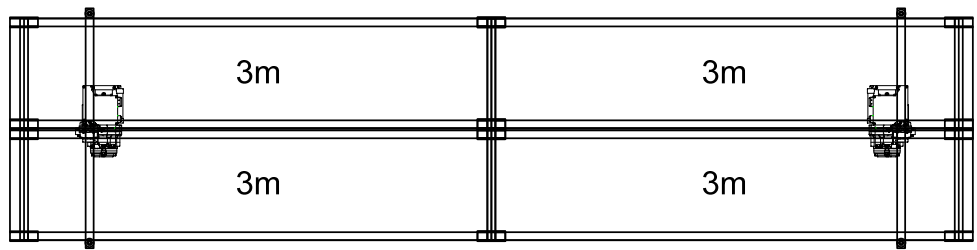
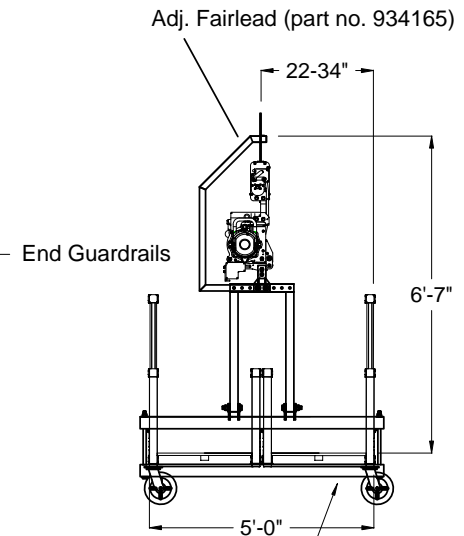
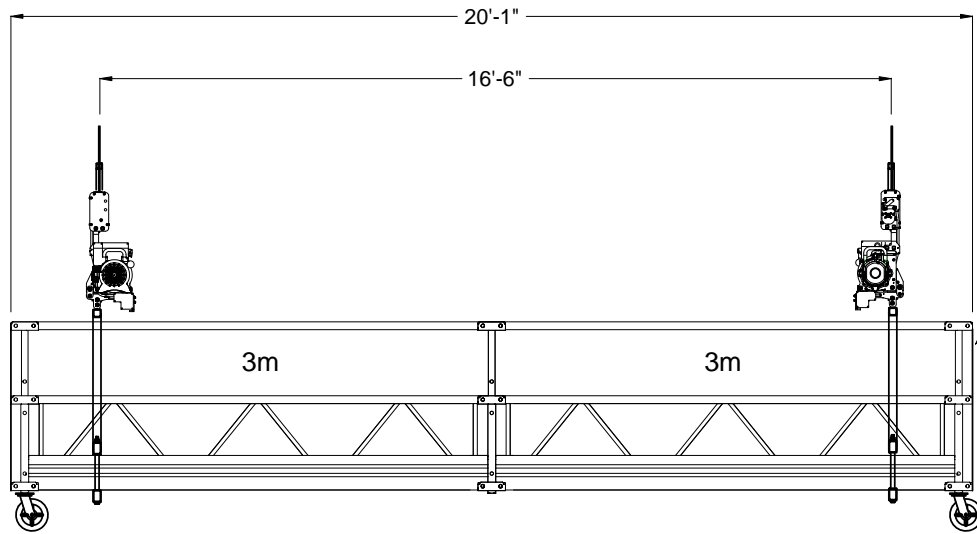

Self Weight approx. 1000 lb

MAX. LOAD CAPACITIES:
 1000 lb distributed load using 1000 lb hoists
 2000 lb distributed load using 1500 lb hoists
 150 lb/linear ft max. point load

If platform still tilts excessively,
 install midrail counterweight brackets
 and add counterweights sufficient
 to properly balance the platform.

DESCRIPTION		20 ft Double Wide Platform	
PART NO.		DATE	7/14/14
SCALE		1/4"=1'	REVISION NO.
DRAWN BY	THIS DRAWING IS THE PROPERTY OF BEE ACCESS PRODUCTS AND IS NOT TO BE COPIED OR REPRODUCED WITHOUT THE CONSENT OF BEE ACCESS PRODUCTS.		
TDJ			
 Bee Access Products			

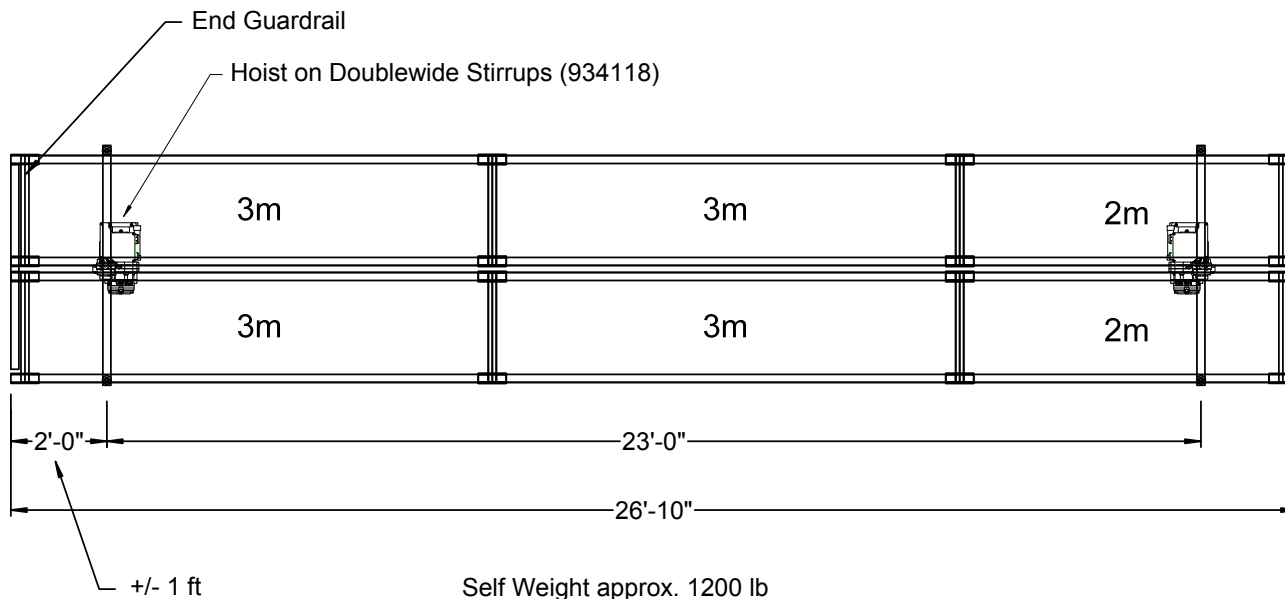

Self Weight approx. 1200 lb

MAX. LOAD CAPACITIES:
 800 lb using 1000 lb hoists
 1200 lb distributed load using 1500 lb hoists
 Max. 750 lb on each parrallel platform

Optional for added stability:
 Adj. Fairlead (part no. 934165)

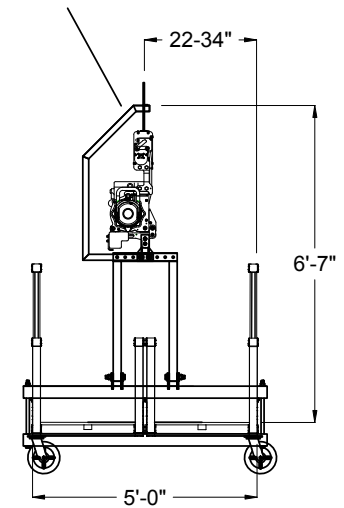

If platform still tilts excessively,
 install midrail counterweight brackets
 and add counterweights sufficient
 to properly balance the platform.

DESCRIPTION		8 m Doublewide Platform	
PART NO.		DATE	5/21/15
SCALE		REVISION NO.	
1/4"=1'			
DRAWN BY	THIS DRAWING IS THE PROPERTY OF BEE ACCESS PRODUCTS AND IS NOT TO BE COPIED OR REPRODUCED WITHOUT THE CONSENT OF BEE ACCESS PRODUCTS.		
TDJ			
 Bee Access Products			