



2145 Indian Road, West Palm Beach, FL 33409
Phone: 561.616.9003 www.beeaccess.com

SPEC-934102

END STIRRUP



DESCRIPTION

Practical! A simple and lightweight solution for mounting traction hoists at the end of platforms.

Simple! The End Stirrup pivots under load to allow the hoist to remain inline with the suspension points if the platform is out of level. The “hats” allow the End Stirrup to be stabilized in an upright position when there is no tension or load on the hoist.

Strong! A tough steel construction with 1,500 lb load capacity.

SPECIFICATIONS

Part No.: 934102

Load Capacity: 1,500 lb

Dimensions: 38.81" x 30.12" x 2.25" (HxWxD)

Weight: 34 lb

Construction: Steel

Finish: Galvanized

1 2 3 4 5

A B C D

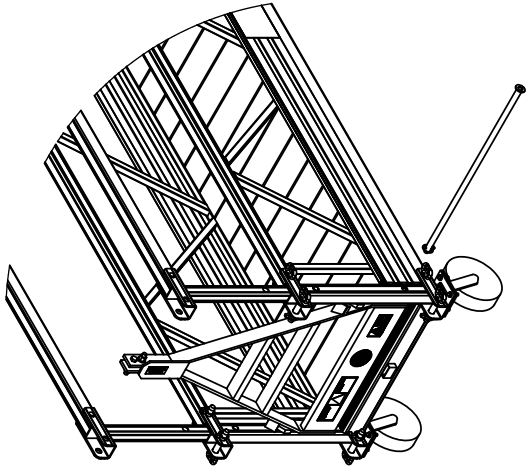

Step #1:

Rest the End Stirrup on the U-Frame tabs located on the inside of the U-Frame and insert the casters in the bottom of the U-Frame

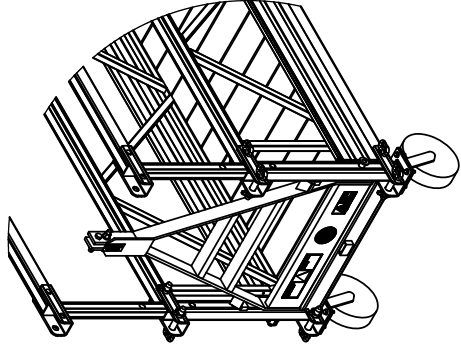

Step #2:

Slide the Stirrup Rod through the U-Frame, End Stirrup and casters, and lock into place via the lynch pin

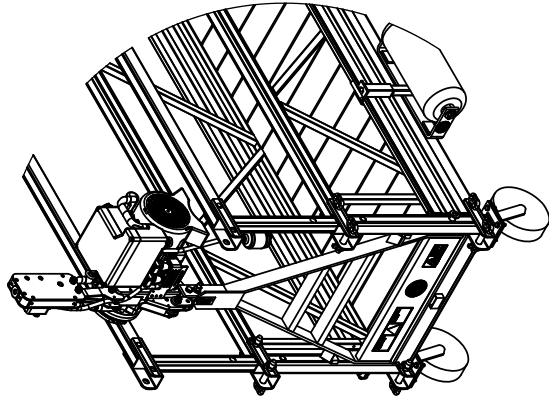

Step #3:

When the End Stirrup is properly secured and resting on the U-Frame tabs, mount the traction hoist with the 1/2" hardware supplied

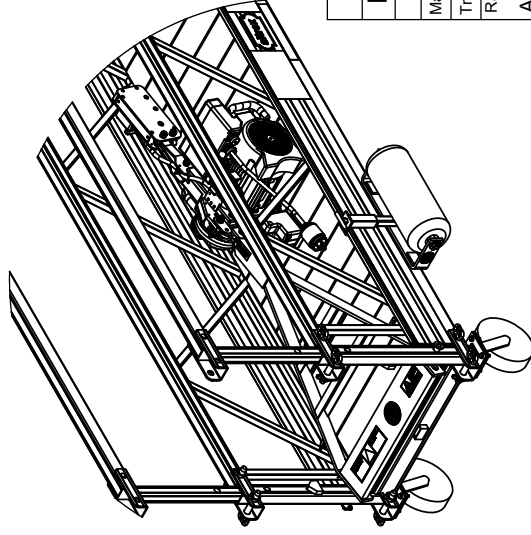

Step #4:

While transporting the platform, rest the End Stirrup and hoist on the platform deck as shown to prevent injury or death

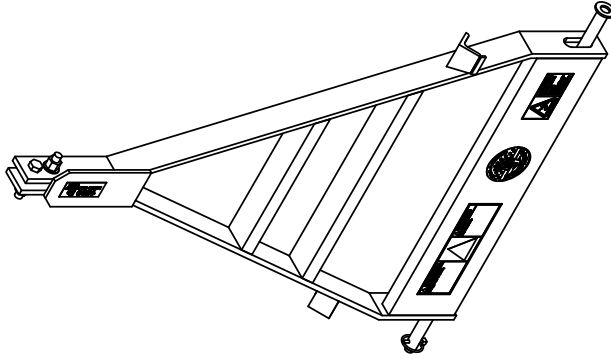

1,500 lb Maximum Load Capacity

A	Redrawn in 3d	SBS	09-25-15
REV	Revision Description	By	Date
DEBUR AND BREAK SHARP EDGES		Bee Access Products	
Material: Assembly		Weight: 284 LBS	
Treatment: N/A		Dimensions in [] are in mm Tol. ISO 2768-m	
Raw material part number:		>	0.5 6 30 120 400
Assembly		<	6 6 30 120 400
Scale Size: 1:25 B/A3		TOL. ±0.1 ±0.2 ±0.3 ±0.5 ±0.8	
Machined surfaces: 12.5		ISO 1302	
CAD generated drawing. Do not manually update. Do not scale drawing.			
Unless otherwise stated tolerances in inches		Product Line/Project	
Approvals	By: Date:	Fractions	Decimals
Drawn	SBS 09-25-15	X ± .060	ALL ± .5°
Approved	08-19-16	XX ± .015	XXX ± .005
Platform		REV. A	
Part No. 934102 App		Sheet 1 of 1	

End Stirrup Application

The information contained in this drawing is the sole property of Bee Access Products. Any reproduction in part or whole without the written permission of Bee Access Products is strictly prohibited.